

### Description

- Mold to width radius belt 4" (101.4 mm) wide
- For radius and straight conveying
- Collapse factor 8.5
- 24% open area
- 38% open contact area
- largest opening 5.9 x 10.7 mm (0.23"x0.42")
- Easy to clean
- Smart Fit rod retention
- Rod diameter 5 mm (0.2")
- Lug teeth sprockets

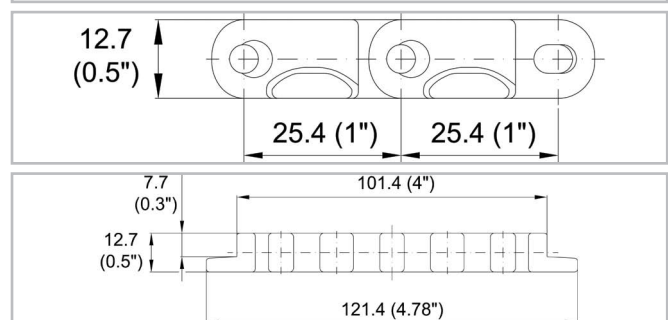
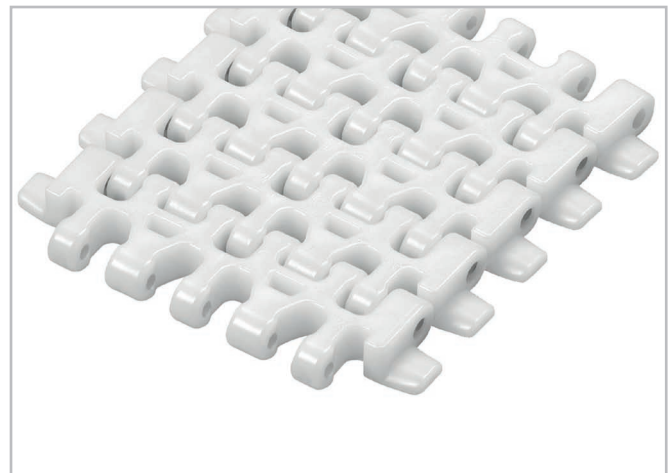

### Belt data

	Nominal belt width $b_0$		Belt material	Rod material	Nominal tensile strength $F_N$ straight run		Nominal tensile strength $F_N$ in curve <sup>(1)</sup>		Belt weight $m_B$	
	mm	inch			N	lbf	N	lbf	kg/m	lb/ft
M2791K04	101.4	4.0	POM	PA	1500	338	1500	338	1.18	0.79
M2791K04	101.4	4.0	POM	PBT	1500	338	1500	338	1.18	0.79

Real belt widths are in most cases 0.1% to 0.3% smaller.

Diameter of idling rollers (minimum)		Diameter of support rollers (minimum)		Diameter for gravity take-up and center drive rollers (minimum)		Backbending radius for elevators without sideguards or hold down devices (minimum)	
mm	inch	mm	inch	mm	inch	mm	inch
40	1.6	50	2	100	4	150	6

### Temperature range

Module material	Rod material	Temperature range	
POM	PA	-40 °C to +93 °C	-40 °F to +200 °F
POM	PBT	-40 °C to +93 °C	-40 °F to +200 °F

**For detailed material properties** refer to the HabasitLINK® Engineering Guidelines.

**The nominal tensile strength** is valid for 23 °C (73 °F). The admissible tensile force depends on the operating temperature near the drive sprockets. Within the temperature range allowed, the admissible tensile force may vary from 100% to 20% of the nominal tensile strength. For detailed information and correct calculation of effective tensile force refer to the Calculation Guide in the HabasitLINK® Engineering Guidelines.



### **Disclaimer**

#### **Product Application Disclaimer (valid for ALL Habasi products and mentioned on all PDS)**

This disclaimer is made by and on behalf of Habasi and its affiliated companies, directors, employees, agents and contractors (hereinafter collectively "HABASIT") with respect to the products referred to herein (the "Products"). SAFETY WARNINGS SHOULD BE READ CAREFULLY AND ANY RECOMMENDED SAFETY PRECAUTIONS BE FOLLOWED STRICTLY! Please refer to the Safety Warnings herein, in the Habasi catalogue as well as installation and operating manuals. All indications / information as to the application, use and performance of the Products are recommendations provided with due diligence and care, but no representations or warranties of any kind are made as to their completeness, accuracy or suitability for a particular purpose. The data provided herein are based on laboratory application with small-scale test equipment, running at standard conditions, and do not necessarily match product performance in industrial use. New knowledge and experience may lead to re-assessments and modifications within a short period of time and without prior notice.

EXCEPT AS EXPLICITLY WARRANTED BY HABASIT, WHICH WARRANTIES ARE EXCLUSIVE AND IN LIEU OF ALL OTHER WARRANTIES, EXPRESS OR IMPLIED, THE PRODUCTS ARE PROVIDED "AS IS". HABASIT DISCLAIMS ALL OTHER WARRANTIES, EITHER EXPRESS OR IMPLIED, INCLUDING, BUT NOT LIMITED TO, IMPLIED WARRANTIES OF MERCHANTABILITY, FITNESS FOR A PARTICULAR PURPOSE, NON-INFRINGEMENT, OR ARISING FROM A COURSE OF DEALING, USAGE, OR TRADE PRACTICE, ALL OF WHICH ARE HEREBY EXCLUDED TO THE EXTENT ALLOWED BY APPLICABLE LAW. BECAUSE CONDITIONS OF USE IN INDUSTRIAL APPLICATION ARE OUTSIDE OF HABASIT'S CONTROL, HABASIT DOES NOT ASSUME ANY LIABILITY CONCERNING THE SUITABILITY AND PROCESS ABILITY OF THE PRODUCTS, INCLUDING INDICATIONS ON PROCESS RESULTS AND OUTPUT.